



X30

# THE COOLANT HEATER OF CHOICE

introducing



## X30 IS SMARTER

Proheat X30 is the most advanced diesel powered heating solution for reliable cold weather starting, fluid heating and passenger comfort. Featuring on board O<sub>2</sub> feedback, X30 automatically adjusts for the best possible combustion to suit the environment.

Whether temperature, altitude,

or system requirements, X30 can adapt to nearly any situation. With more than 20 years of field experience, Proheat X30 is truly the next generation of smart heater.

### Basic System

- 1 X30 Heater
- 2 Switch or Timer (PFC)
- 3 Heated Engine
- 4 Cold Coolant Return
- 5 Fuel Pick-Up
- 6 Battery Supply
- 7 Exhaust

### Heating Options

- 8 Thermostat
- 9 Heat Exchanger
- 10 Heat Probe
- 11 Hydraulic Tank

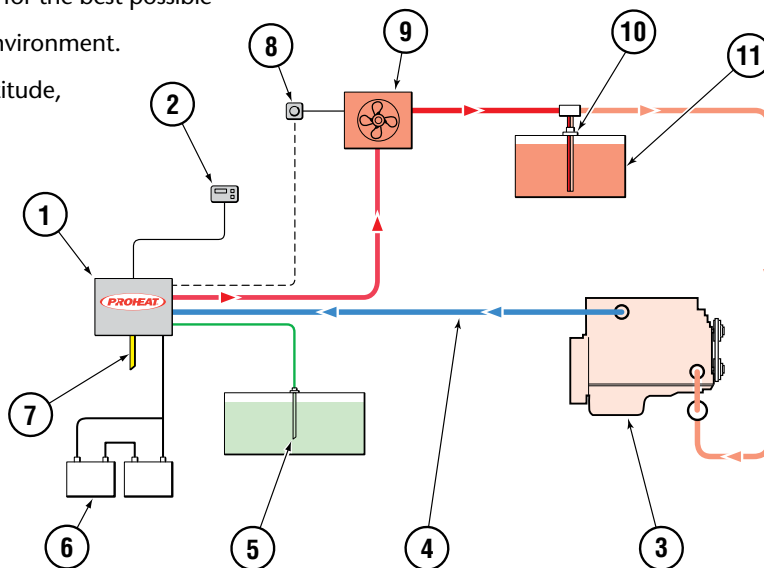

## AT A GLANCE

### COOLANT HEATER FEATURES

- 10–31kBTU/hr variable heat output
- O<sub>2</sub> feedback for optimum combustion with minimal emissions
- Low pressure fuel system for safe reliable starting under all conditions
- Flexible mounting options to suit many different applications
- Next generation programmable PCM controller
- J1939 CAN bus network
- New operating modes to save battery power and fuel
- Two year parts and labor warranty



www.proheat.com



**X30**

**SPECIFICATIONS**

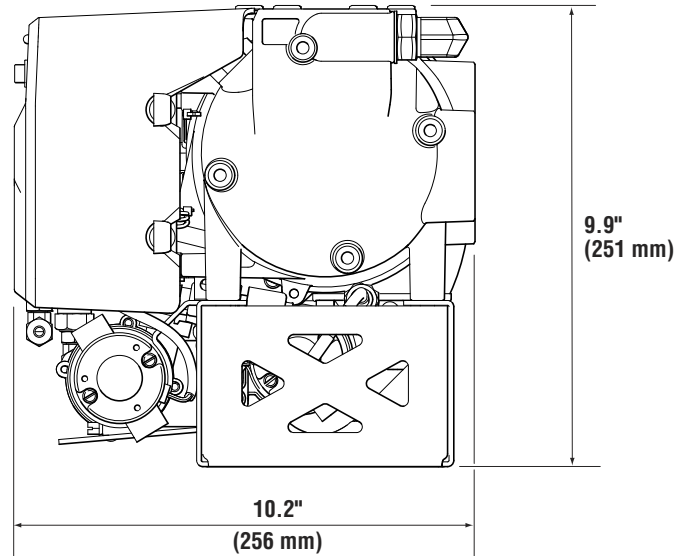
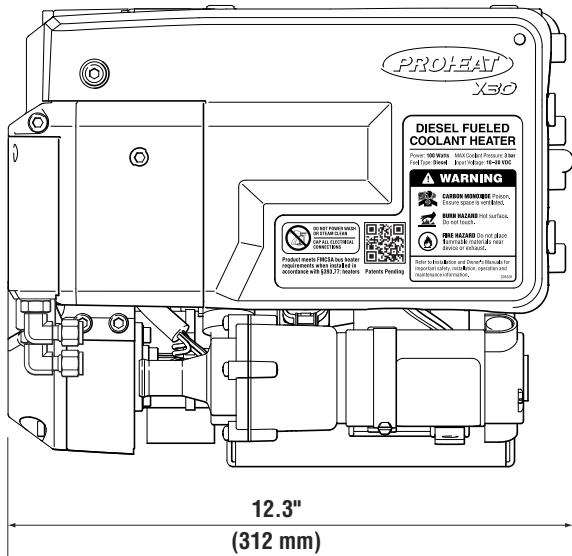

RATING	10,000 – 31,000 BTU/hr (2.9 – 9.1 KW)
OPERATING VOLTAGE RANGE	10 – 30 VDC
POWER CONSUMPTION	90W max. (7.5A @ 12VDC, 3.8A @24VDC)
FUEL CONSUMPTION	0.1 – 0.31 gal/hr. (0.4 – 1.17 L/hr.)
COOLANT FLOW (minimum)	3.0 gal/min. (11.4 L/min.)
COOLANT TEMPERATURE (at heater)*	150 to 185 °F (65 to 85 °C)
OPERATING TEMPERATURE RANGE	-40 to 185°F (-40 to 85°C)
FUEL TYPES	Diesel (ULSD #1, #2 and Arctic Blend), Kerosene (K-1), Jet (A, A-1 and JP8), Bio fuels (up to B20)
IGNITION TYPE	Electronic spark ignition
HEAT EXCHANGER CAPACITY	0.36 quart (0.34 litre)
WEIGHT	heater only with enclosure
	36 lb (16.3 kg) 44 lbs (20 kg)
DIMENSIONS – HEATER (L x W x H)	12.3 x 10.2 x 9.9 inches (312 x 256 x 251 mm)
DIMENSIONS – ENCLOSURE (L x W x H)	13.25 x 11.25 x 11 inches (337 x 286 x 279 mm)
WARRANTY	Two years parts and labor

**PROHEAT X30 KITS**

<b>BASIC HEATER</b>	<b>PH0310</b>
<b>STANDARD HEATER KIT NO ENCLOSURE</b>	<b>PH0320</b>
Includes: Items 1 and 2	
1. BASIC HEATER	PH0310
2. INSTALLATION KIT	PK3003
<b>STANDARD HEATER KIT WITH ENCLOSURE</b>	<b>PH0330</b>
Includes: Items 1, 2 and 3	
1. BASIC HEATER	PH0310
2. INSTALLATION KIT	PK3003
3. ALUMINUM ENCLOSURE	PK3002

Please Note: Specifications are subject to change without notice.

\* Optional set points available.



Optional Proheat Function Controller (PFC) PK3000



Aluminum Enclosure PK3002



Installation Kit PK3003

Proheat is registered trademark of Marine Canada Acquisition Inc. and its subsidiary companies.



Designed and Manufactured in North America

